



# Radio transponder readers NB403/NB540 and NB688N/NB693N

## Installation and operation instructions



These instructions are to be passed on by the fitter to the user

## Contents

1	Applications .....	3
2	Delivery scope .....	4
3	Installation advice .....	5
3.1	Terminal connection diagrams .....	5
3.2	Routing dimensions/drilling jig .....	5
3.3	Mounting the cover .....	6
4	Commissioning.....	7
4.1	Power supply connection .....	7
4.2	Delivery status .....	7
4.3	Two transmitting channels for different devices/doors .....	7
5	Tuning in and deleting .....	8
5.1	Operating the user transponder .....	8
5.2	Tuning in the radio transponder reader with a <b>multitronic/autotronic</b> control with radio receiver .....	9
5.3	Tuning in further user transponders with the master transponders .....	10
5.4	Tuning in a car key as an additional user transponder with the radio transponder reader NB403/NB688N .....	11
5.5	Deleting individual user transponders with the master transponders .....	12
6	Tamper protection .....	13
6.1	Blocking times as a tamper protection .....	13
7	Resetting the radio transponder reader .....	14
7.1	Deleting all user transponders with the master transponders .....	14
7.2	Deleting all user/master transponders and the radio code with the reset button .....	14
7.3	Tuning in both master transponders afresh for radio channels 1 and 2 .....	15
8	Important advice .....	16
8.1	Power failure .....	16
8.2	Maintenance and care .....	16
8.3	Liability .....	16
8.4	Technical specifications .....	16

## Caption

LED display example:



LEDs do not light up.



Green LED flashes.



Red LED flashes.



Green LED lights up,  
Red LED flashes.



Green LED lights up for  
2 sec.



Important information;  
please note.



Instructions in further languages,  
refer to [www.fuhr.de](http://www.fuhr.de)

# 1 Applications

The radio transponder readers NB403/NB540 and NB688N/NB693N are convenient, modern and secure access control systems for contact-free switching of FUHR motorised locks.

For further connection options, an additional mains-operated power-socket radio-receiver (item no. NZ80088) or a universal radio-receiver (item no. NZ80023) can be integrated in the **multitronic/autotronic** system, controlled via the radio transponder reader.

The opening impulse is transmitted wirelessly via an encrypted and high-performance radio signal from the radio transponder reader, as soon as an authorised transponder is held in front of the radio transponder reader.

A completely preassembled device is included in this set which is immediately ready for operation after installation and has been connected up to a 12 V DC power supply. Both of the master transponders and the three user transponders have already been tuned in to the radio transponder reader in our factory. Furthermore, the radio transponder readers NB403 and NB688N provide you with an additional feature: Depending on the type of car, you can tune in your car key and use it as a new user transponder! Upon connecting your device to the power supply, you can easily determine whether your car key can be detected. For more on this, refer to page 11, chapter 5.4.

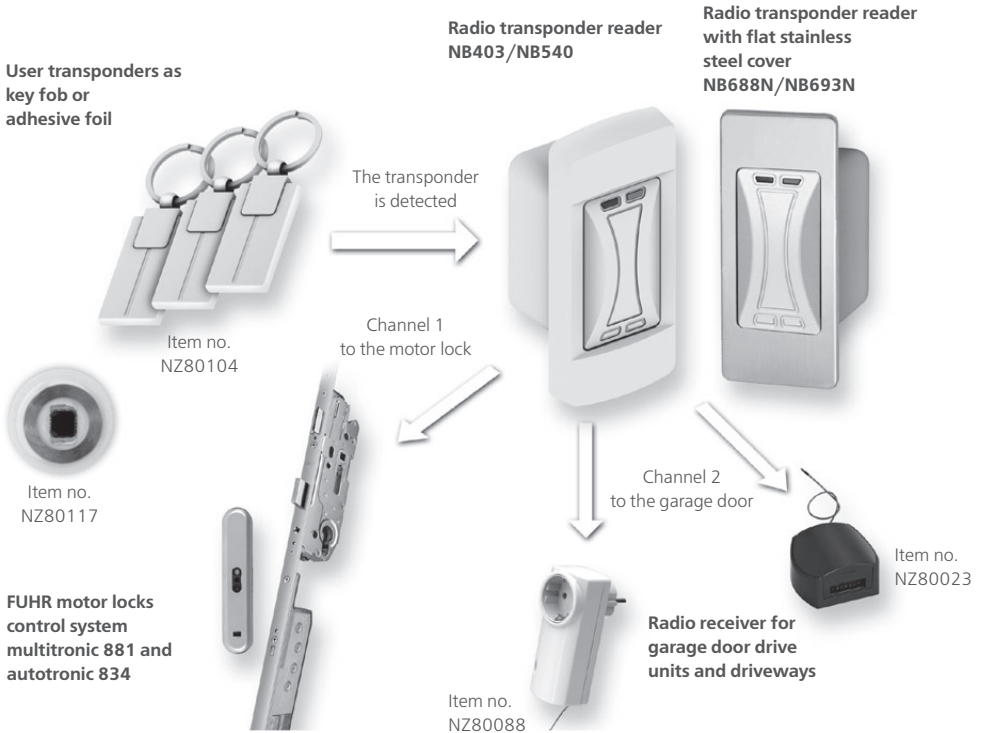

Please read these installation and operating instructions both carefully and thoroughly, as they contain important installation, operating, and safety information, that is essential for the operation and safety of your new access control system!

## 2 Delivery scope

### A FUHR radio transponder reader as set NB403/NB540

A	1 piece	Radio transponder reader with LED display + connection cable
B	1 piece	Master transponder card for radio channel 1 (no batteries needed)
C	1 piece	Master transponder card for radio channel 2 (no batteries needed)
D	3 pieces	User transponder (no battery needed)

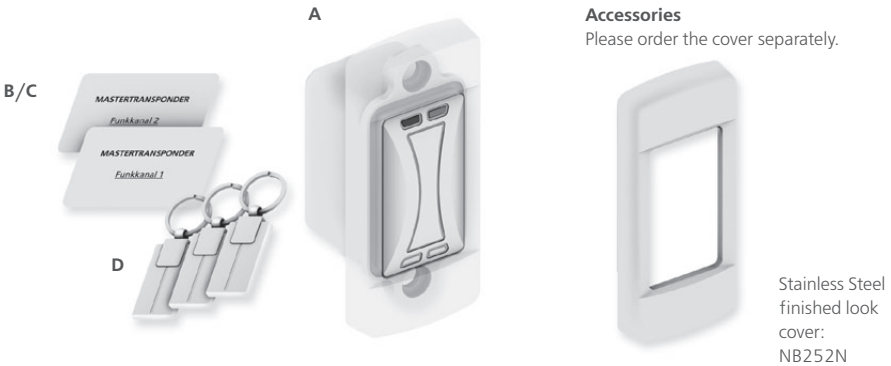

### B FUHR radio transponder reader as set NB688N/NB693N

A	1 piece	Radio transponder reader with flat stainless steel cover, LED display + connection cable
B	1 piece	Master transponder card for radio channel 1 (no batteries needed)
C	1 piece	Master transponder card for radio channel 2 (no batteries needed)
D	3 pieces	User transponder (no battery needed)

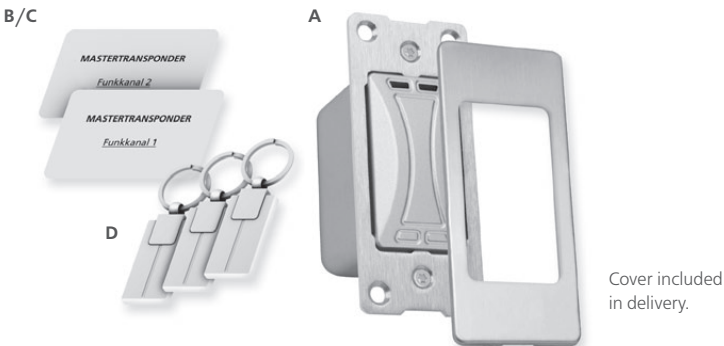

### 3 Installation advice

#### 3.1 Terminal connection diagrams

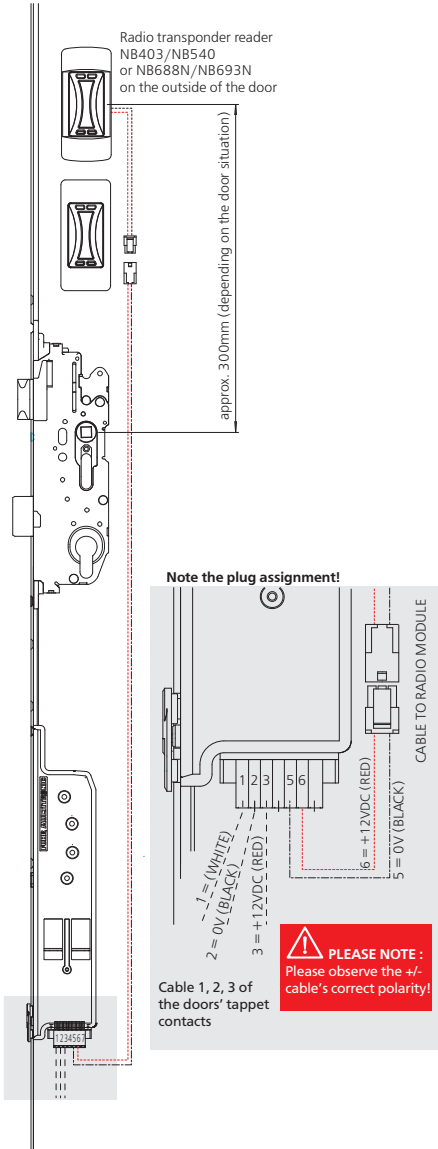

#### 3.2 Routing dimensions/ drilling jig

##### A NB403/NB540

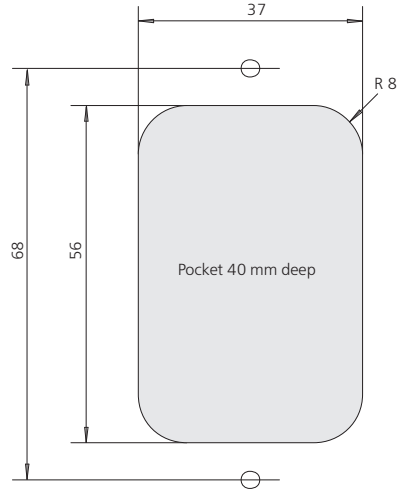

##### B NB688N/NB693N

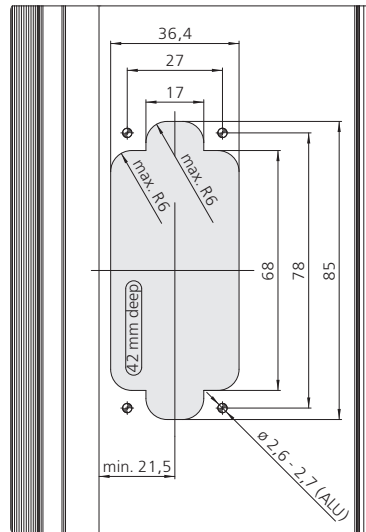

### 3.3 Mounting the cover

#### A NB403/NB540

After screw-fixing the radio transponder reader to the door profile, attach the top of the cover at an angle (accessory part NB252N) and attach with both of the enclosed grub screws.

**Please note:** Hand-screw the grub screws with the 2 mm Allen key using little force, in order to avoid deforming the radio transponder reader's housing.



#### B NB688N/NB693N

**Please note: Before fixing the cover it is imperative to observe the following:** Affix the cover not until all other installing steps were finished and the transponder was successfully tuned in to the radio receiver. Removing the cover after fixing may result in damaging the cover.

Replacement cover:  
Item no. NB28052N

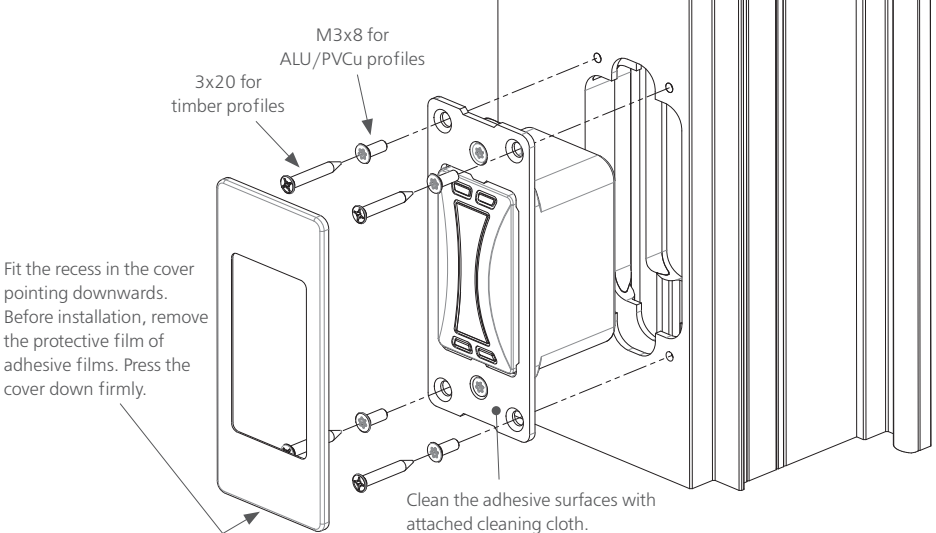

## 4 Commissioning

### 4.1 Power supply connection

The radio transponder reader requires 12 V DC (direct current) operating voltage, collected directly from the motor lock's drive unit. For more on this, refer also to page 6, chapter 3.3.  
Terminal 5 = - pole, terminal 6 = + pole.



**Please note!**  
**Please observe the correct polarity (+/-) to the power source!**



### 4.2 Delivery status

Both the master transponders and the user transponders enclosed in the set have already been tuned in to the radio transponder reader in the factory.

In addition, the master transponders have been labelled with "radio channel 1" and "radio channel 2" at the factory. The master cards are only used for tuning in and deleting user transponders. These cannot be used to open motor locks.

All three user transponders have been tuned in to "radio channel 1" at the factory. These user transponders can as a result only be used to open motor-lock doors.

Upon connecting up the 12 V DC operating voltage, these user transponders that have already been tuned in, can be used immediately to create a radiotelegram.

In order to open the motor-lock door with the radio transponder reader, it is imperative to note page 9 in chapter 5.2.

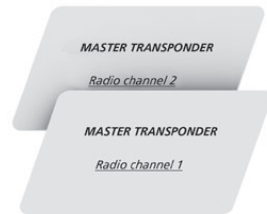

### 4.3 Two transmitting channels for different devices/doors

The radio transponder reader is capable of transmitting opening impulses on two different channels. This results in the advantage of being able to control two different devices with one radio transponder reader.

**Channel 1** For the **multitronic/autotronic** main door

**Channel 2** For another **multitronic/autotronic** door or, in conjunction with the FUHR radio receiver NZ80023/NZ80088 (refer to page 3, chapter 1), for a motorised garage door drive unit or an electrical yard gate.

A user transponder can always only be tuned in to one of the two channels; never for both channels simultaneously. If you would like to control two different doors with one transponder reader, you must use two different user transponders.

## 5 Tuning in and deleting

### 5.1 Operating the user transponder

The radio transponder reader needs approx. 1 second to detect and read the transponder.

Centrally position the enclosed user transponder at a right angle in front of the radio transponder reader as depicted in the illustration.

In doing so, hold the transponder as near as possible to the radio transponder reader; however you don't have to touch it.

Depending on the transponder's type and design, the reading distance is between 0 and 30 mm.



Channel 1



Channel 2



If the user transponder has **already been stored in the radio transponder reader on channel 1**, the green LED lights up permanently for 2 seconds and then goes out. In doing so the radio transponder reader automatically transmits a radiotelegram to channel 1.

If a user transponder has **already been tuned in to channel 2**, the green LED lights up twice for 1/2 a second when it is used. As a result, you can visually recognise which radio channel the user transponder has been tuned into.

If the user transponder has **not already been stored in the radio transponder reader**, the red LED lights up for 2 seconds and then goes out. In doing so the radio transponder reader transmits no radiotelegram.



## 5.2 Tuning in the radio transponder reader with a **multitronic/autotronic** control with radio receiver

In order that your radio transponder reader can open the FUHR motor lock, it needs to be tuned in to the **multitronic/autotronic** control just once. The radio transponder reader is tuned in in exactly the same manner as a new radio key. (For more information refer to the **multitronic 881/autotronic 834** installation and operating instructions.)

An abridged version of the tuning in procedure:

1. Hold the master radio key in your hand (the one with the red buttons).
2. Press the tune-in button **briefly (for approx. 1 second) (A)** between the LED's on the **multitronic/autotronic** control positioned on the inside of the building. The green LED **(B)** on the **multitronic/autotronic** control begins to flash! Ensure that the doors' tappet contacts touch the surface-contact in the door frame during this procedure. **Step 3 and 4 must each be carried out within 20 seconds.**
3. Now go to the outside radio transponder reader and activate the master radios key's (with the red buttons) previously tuned in button. (If the control accepts the master radio key, the **multitronic/autotronic** control's green LED **(B)** lights up initially for 2 seconds and then continues to flash.)
4. Now hold one of the **previously tuned in user transponders for 5 seconds in front of the radio transponder reader**. In doing so, the radio transponder reader's LED must briefly flash twice. In the process the radio transponder reader transmits two encrypted radio signals to the **multitronic/autotronic** control, whereby both components are then connected with each other.



**Advice:**

**If you need more than 20 seconds each for both step 3 and step 4, the tuning in procedure is aborted and you must start again at step 1.**  
**If the tuning in procedure has been carried out correctly, the motor lock door can now be opened with the tuned in channels' user transponders.**

**multitronic/autotronic control with radio receiver and visual locking display**

- A Tune-in button
- B Green LED
- C Red LED
- D Master radio key

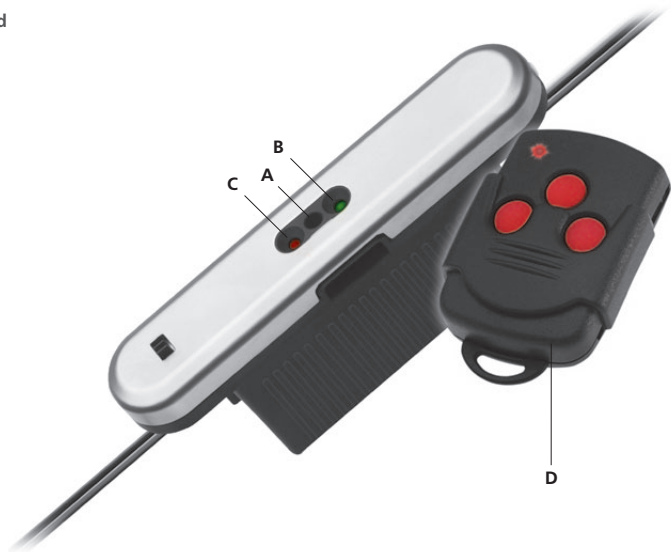

### 5.3 Tuning in further user transponders with the master transponders

You can tune in more user transponders to the radio transponder reader at any time with the help of the two master transponders enclosed for the radio channels 1 and 2.

**Maximum 200 user transponders (100 per channel) can be tuned in!**

Proceed as follows to tune in a new user transponder:



1. Hold the desired radio channel's (1 or 2) master transponder for approx. 1 second directly parallel in front of the radio transponder reader. The red and green LED flash briefly together once, and then light up permanently for 20 seconds. **Remove the card again from the radio transponder reader.**
2. **Within these 20 seconds** hold the user transponder that you want to tune in directly in front of the radio transponder reader. If the user transponder is detected, the green LED lights up permanently. Now remove the user transponder again.
3. Now hold the master transponder you used in step 1 again directly in front of the radio transponder reader **within 20 seconds**. Now in addition, the red LED will light up for 3 seconds. After this both LED's will go out again. The new user transponder's tuning in procedure has been successfully completed.

A successful tuning in procedure can be tested by once again holding up the user transponder in front of the radio transponder reader. If the radio transponder reader detects the user transponder, the green LED lights up for 2 seconds and simultaneously transmits a radiotelegram.



**Note:**

**If your radio transponder reader has not been tuned in to the multitronic/autotronic control's radio receiver, the radio transponder reader's green LED will indeed light up upon using a user transponder, but your motor-lock door will not react.**

Find out more on how to tune in the radio transponder reader to the multitronic/autotronic control's radio receiver on page 9, chapter 5.2.

## 5.4 Tuning in a car key as an additional user transponder with the radio transponder reader NB403/NB693N

Apart from the user transponders supplied, the radio transponder reader NB403 or NB693N can also recognise several leading car manufacturers' keys. This has the distinct advantage that you can easily open your main door with your car key and that you no longer need an additional user transponder! You tune in the car keys just like normal user keys.

The following is a selection of some car brands that, as the case may be, are equipped with suitable transponders.

### Car Brands

Audi

BMW

Mini

Porsche

Renault

Volkswagen



#### Note:

**Given the fact that the car manufacturers change their transponders depending on the car model and year of manufacture, we regrettably cannot guarantee that all models/keys listed here can be detected!**

You can easily determine whether or not your car key is equipped with a detectable transponder or not:

To do so, connect up the radio transponder reader to the 12 V DC power supply. Then hold your car key flat up against the radio transponder reader. Wait for approx 1 second, to see whether the red LED lights up or not. If this is the case, the radio transponder reader detected the car key, and you can tune it in as an user transponder, as described on page 10, chapter 5.3.

If the radio transponder reader doesn't detect the key on the first try, this could be due to the car key's disadvantageous positioning in relation to the radio transponder reader. In order to test this, repeatedly move your car key into another position and hold it up again close in front of the radio transponder reader for 1 second until you establish the best position in which the radio transponder reader can detect the transponder.

## 5.5 Deleting individual user transponders with the master transponders

You can delete previously tuned in user transponders from the radio transponder reader at any time with the help of the two master transponders enclosed for the radio channels 1 and 2.

Proceed as follows to delete a previously tuned in user transponder:

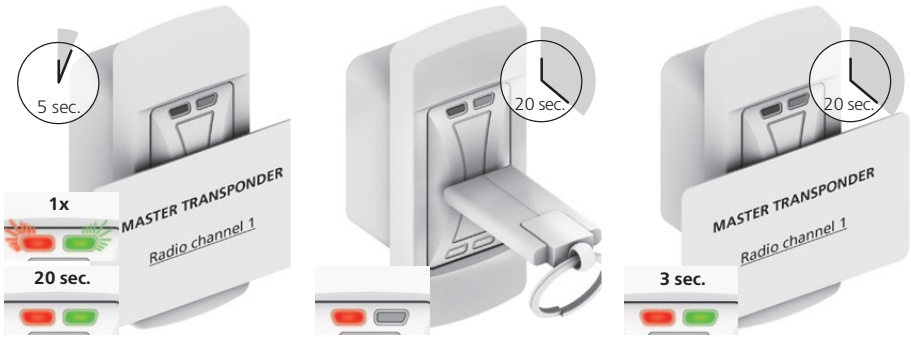

1. Hold any **master transponder** for approx. **5 seconds** directly parallel in front of the radio transponder reader and **remove it again immediately**. The red and green LED flash briefly together once, and then light up permanently for 20 seconds.
2. **Within these 20 seconds** hold the user transponder that you want to delete directly in front of the radio transponder reader. If the user transponder to be deleted is detected, the red LED lights up permanently. Now remove the user transponder again.
3. Now **within 20 seconds**, hold the master transponder you used in step 1 again parallel up close in front of the radio transponder reader for approx. **3 seconds** and remove it again immediately. Now in addition, the green LED will light up for 3 seconds. After this both LED's will go out again. The user transponder's delete process has been successfully completed.

**Test:** Whether the deletion procedure was successful or not can be tested by once again holding up the user transponder in front of the radio transponder reader.

If the radio transponder reader doesn't detect the user transponder anymore, the red LED lights up for 2 seconds. No radiotelegram is transmitted and the door remains locked.

## 6 Tamper protection

### 6.1 Blocking times as tamper protection

In order to prevent tampering attempts on the system, it switches to an inhibit mode if a non tuned in transponder is used 5 times consecutively. The red LED flashes slowly to indicate that the radio receiver is in this mode. No radio signal is generated during this time and in addition no transponders can be tuned in or deleted. The blocking times are extended automatically if once again a non tuned in transponder is held 5 times in front of the radio transponder reader. The blocking times are extended in the following mode:

5x	Incorrect transponder	1 minute block
10x	Incorrect transponder	5 minute block
15x	Incorrect transponder	30 minute block
20x	Incorrect transponder	60 minute block
25x	Incorrect transponder	Permanent block

In order to end this blocking mode, either one must wait for the time to pass, or hold a tuned in user transponder twice – or a master transponder once – in front of the radio transponder reader for detection.

Subsequently the system switches back again automatically to the standard operation mode.



#### **SAFETY NOTE**

**In the same way as with conventional keys, given enough time and effort transponders can also be reproduced and copied respectively!**

**In order to eliminate abuse and unauthorised copying of your transponder code, hand over neither your supplied user transponder nor master transponder to third parties!**

**This also applies to any tuned in car keys. If you leave your car at the garage, only use the non tuned in garage car-key!**

## 7 Resetting the radio transponder reader

### 7.1 Deleting all user transponders with the master transponders

You can delete all previously tuned in user transponders from the radio transponder reader at any time with the help of the master transponders enclosed. Only the master transponders remain stored. The radio link to the motor lock is not deleted in the process. Proceed as follows to delete all user transponders:

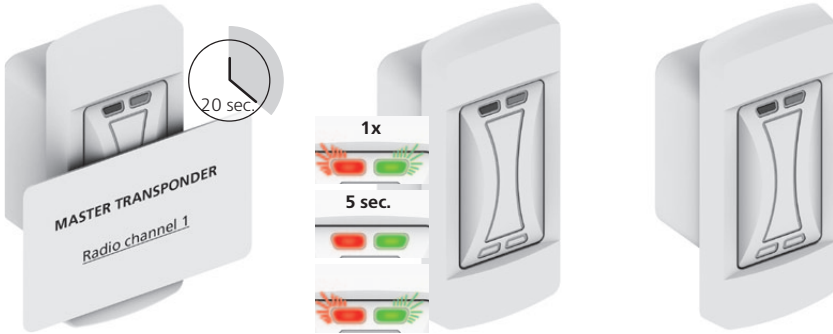

1. Hold any **master transponder** for a **minimum of 20 seconds directly parallel in front of the radio transponder reader**, this way all user transponders from channel 1 and 2 are deleted.

LED displays: At the beginning of these 20 seconds the red and green LED flash briefly together once, and then light up permanently for 5 seconds. After this both LED's flash; at first slowly and then very fast in turn. The delete process has started, you can remove the card again from the radio transponder reader.

2. The device is now back in normal operation. Both LED's go out. You can now tune in user transponders at any time on channel 1 or 2.

### 7.2 Deleting all user/master transponders and the radio code with the reset button

In the removed state, you will find a small reset button on the back of the radio transponder reader. **Pressing this button brings about deleting all user and master transponders, as well as deleting the radio link to channel 1 and channel 2.**

After deletion, firstly both of the master transponders, and then the user transponders have to be tuned in to the radio transponder reader. The radio link to the receiver in the motor-lock door must also be newly established.

Proceed as follows to delete:

**Press the reset button for 20 seconds.** After this time has lapsed, both LED's begin to flash in turn very fast. Subsequently you can let go of the button and wait until the automatic delete process is concluded. This is then the case if the red and green LED light up again permanently.

Now you have to tune in both master transponders for channel 1 and channel 2. For more on this, refer to page 15, chapter 7.3.

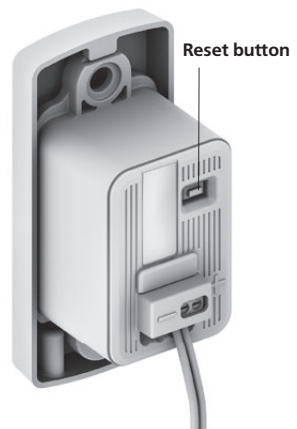

### 7.3 Tuning in both master transponders afresh for radio channels 1 and 2

After a complete reset with the reset button (on the back of the radio transponder reader) in compliance with chapter 7.2 has been carried out, both master transponders for channel 1 and 2 must be tuned in again first. The complete deleted status can be recognised by the fact that both LED's are lit up at the same time. First the master transponder for channel 1 is tuned in, subsequently the master transponder for channel 2.

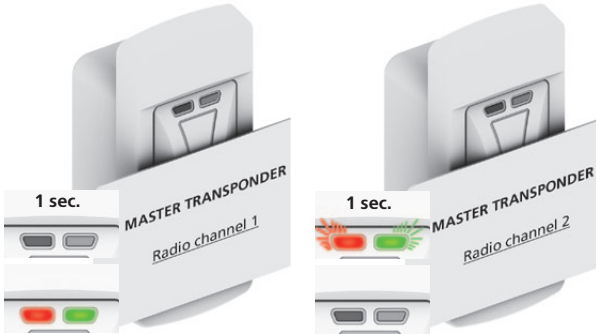

1. **Hold the master transponder "radio channel 1" briefly in front of the radio transponder reader.** As soon as the master transponder has been detected, both LED's go out for 1 second and then light up permanently
2. **Now hold the master transponder "radio channel 2" briefly in front of the radio transponder reader.** As soon as the second master transponder has been detected, both LED's flash for approx. 1 second. Subsequently both LED's go out. The master transponder's tuning in procedure has been successfully completed.

You can now again tune in your user transponders at hand to channel 1 or channel 2 with the help of the master transponder that has just now been tuned in. For more on this, refer to page 10, chapter 5.3.

Please note that you also must establish a connection to the motor-lock door or garage door again. For more on this, refer to page 9, chapter 5.2.

## 8 Important advice

### 8.1 Power failure

A power failure has no effect on the programmed master- or user transponders; they remain tuned in. Opening the door automatically cannot be effected.

**We generally recommend the installation of a mechanical cylinder in the main-lock casing in order to warrant the possibility of mechanical access at all times.**

### 8.2 Maintenance and care

The radio transponder readers NB403/NB540 and NB688N/NB693N are maintenance-free devices. In order to protect the radio transponder reader's surface, no caustic, scouring cleaning agents or solvents may be applied! Remove dirt with mild cleaning agents.

The supplied transponders are maintenance-free as well as being waterproof, and can be operated without batteries.

### 8.3 Liability

Neither the manufacturer nor the sales companies are liable for costs or damages incurred that result from the users or third parties' use of the NB403/NB540 and NB688N/NB693N; particularly resulting from inappropriate use, abuse or faults, as well as assumed or evident device malfunctions.

### 8.4 Technical specifications

Identification carrier:	HITAG2 transponder (integrated in the master- and user transponder)
Operating frequency:	125 kHz
Range:	Approx. 30 mm (depending on the transponder's position)
Operating voltage:	12 V DC
Current consumption:	Approx. 70 mA
Opening impulse:	868.3 MHz radio signal, encrypted as rolling code
Transmitting channels:	2 pieces
Transmitter range:	Approx. 100 m (free field)
Transponder quantity:	Max. 200 pieces (100 per channel)
Dimension:	55 x 36 x 38 mm (H x W x D)
12 V DC cable length:	1600 mm